

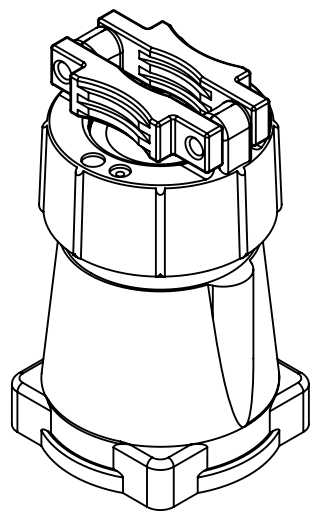

This drawing is the property of MELTRIC Corporation, Franklin (Milwaukee), Wisconsin, USA. Any unauthorized copying of this drawing by any means, ENG/RD/06 REV: 20 ISSUED DATE: 1/15/11 or disclosure of its contents to any person not authorized by MELTRIC Corporation or its agents to receive it, is strictly prohibited.

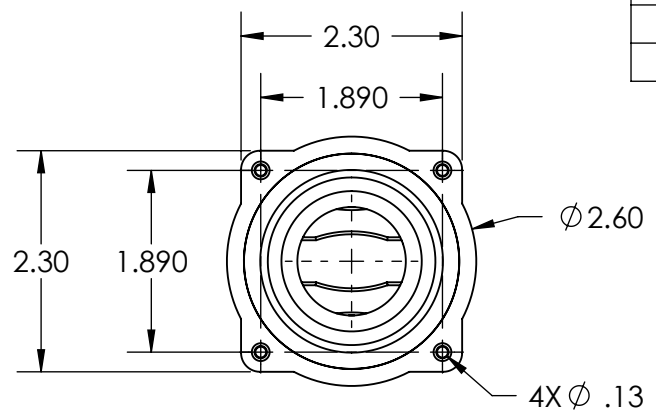

PART NUMBER	CABLE RANGE
712POS14	.750" - .875"
712POS16	.875" - 1.000"
712POS18	1.000" - 1.125"
712POS20	1.125" - 1.250"
712POS22	1.250" - 1.375"

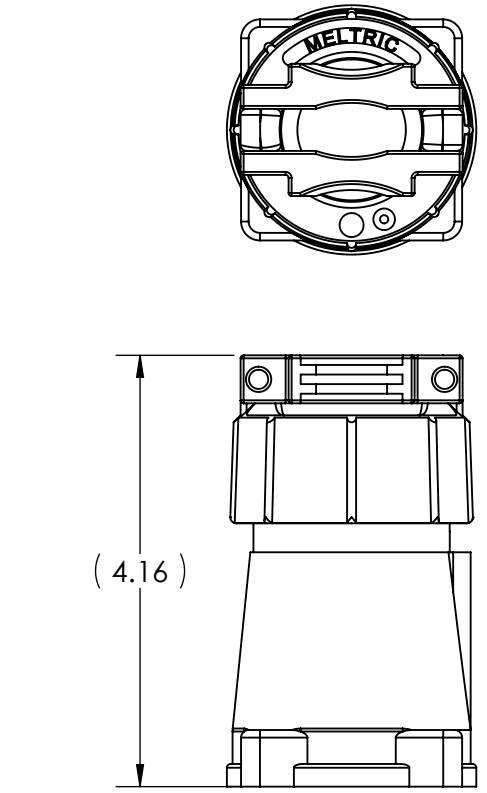
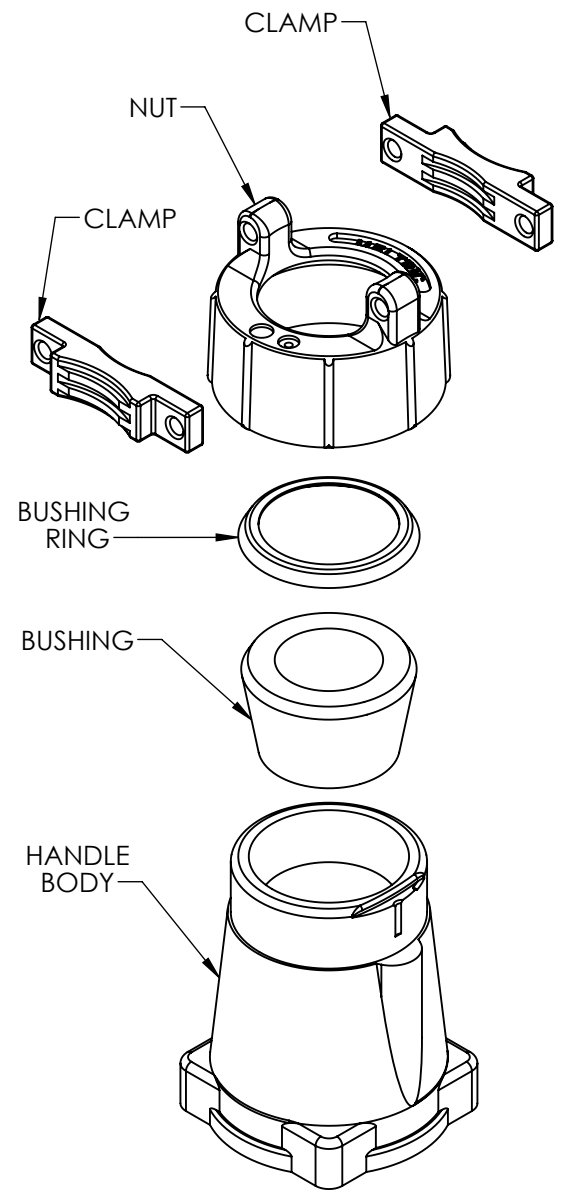

TOLERANCES UNLESS OTHERWISE SPECIFIED	
MACHINED SURFACES $\sqrt[125]{\text{MAX}}$	ENGLISH 0.X ±0.05 0.XX ±0.01 0.XXX ±0.005
GROUND SURFACES $\sqrt[32]{\text{MAX}}$	
ANGLE TOLERANCE ±1°	
REMOVE BURRS & SHARP EDGES TO .015 MAX.	
 DIMENSIONS SHOWN IN OVALS ARE INSPECTION DIMENSIONS.	

		DRAWING TITLE:	
A COMPANY OF MARECHAL ELECTRIC		POLY HANDLE WITH CABLE CLAMP	
DRAWN	APPROVED	SCALE	MATERIAL:
DATE:		NTS	BLUE POLY
SHEET:		PART NUMBER	REVISION
1 OF 1		712POSxx	